

# **Organic Colour Removal Filters**

*OCR 850 and 860 Models*

*Operating and Maintenance Manual*

## Performance and Specifications

Item #	Model	Tannin Removal Capacity ppm	Salt Dosage Lbs/Cu Ft	Flow Rate USGPM	Resin Tank Size Inches	Brine Tank Size Inches	Resin Volume Cu Ft	Salt Capacity Lbs	Shipping Weight Lbs
2030	OCR15-850	3,000	12	4.5	10 x 54	21 x 36	1.5	300	110
2035	OCR20-850	4,000	12	6	12 x 52	23 x 38	2	400	150
2040	OCR30-850	6,000	12	9	14 x 65	23 x 38	3	400	200
2045	OCR15-860	3,000	15	4.5	10 x 54	21 x 36	1.5	300	110
2050	OCR20-860	4,000	15	6	12 x 52	23 x 38	2	400	150
2055	OCR30-860	6,000	15	9	14 x 65	23 x 38	3	400	200

**\* Application must be based on analysis by an authorized USF WaterGroup representative or distributor**

The manufacturer reserves the right to make product improvements which may deviate from the specifications and descriptions stated herein, without obligation to change previously manufactured products or to note the change.

## Application and Installations of Organic Colour Removal Unit

This Organic Colour Removal Filter (OCR) has been designed to remove tannins from your water supply. Tannins can cause a yellow to brown colour in the water (i.e. organic colour) and also may impart taste and odour as well. Tannins are formed by the decomposition of vegetable matter.

All tannins are not equal, and thus the type of OCR unit selected should have been with the assistance of an authorized representative or distributor. This is typically done based on a water analysis and column testing of the source water and/or with experience on other successful installations in the area on the same source water.

### Application Notes about OCR Units:

- Although the OCR unit selected through a proper water analysis and testing was the most suitable type for the application, total removable of all colour contaminants may occasionally not be attained due to:
  - Multiple types of tannins in the source water. OCR Unit media may only be successful at removing some of these organics, but not all.
  - Colour may be caused by contaminants other than organics.
  - The remaining contaminants may require removal by other methods such as activated carbon, reverse osmosis, etc. Please consult your authorized representative or distributor for solutions.
- If water hardness is also present (particularly if total hardness > 10 grains/US Gal), a softener must be installed ahead (upstream) of the OCR unit. Without the softener, the OCR resin bed is prone to fouling by the precipitation of calcium carbonate. Meter initiated softeners with a reserve capacity are preferred to calendar clock softeners to ensure the softener is not overrun.
 

**(Installation Tip: Ensure that the OCR Unit is only allowed to regenerate after the regeneration of a water softener if one is present)**
- Metals in the water such as Iron and Manganese can also foul the OCR resin bed, reducing the ability to remove tannins. An iron filter or iron guard softener should be used to reduce the problem causing contaminants to an acceptable level.
 

**(Installation Tip: As in item #2, the OCR Unit and any softeners and filters should not be allowed to regenerate at the same time. Consult the applicable unit owners manuals on regeneration time and adjustment if necessary.)**
- Turbidity caused by suspended solids and sediment can foul the OCR resin bed. Removal of the turbidity can be achieved through some type of mechanical filtration such as a multi-media filter and/or cartridge filters.
- Depending on the Alkalinity of the source water being treated, the pH of the water after the OCR unit will likely drop for part or all of the units service run after regeneration. This is caused by the OCR unit's resin ability to also remove alkalinity in the water. Adjustment of the waters pH may be required once treated by the OCR unit.
- If "nitrates" are present in the source water, consult your authorized representative or distributor for additional solutions.
 

**(Caution: This unit has not been designed for nitrate removal and should be dealt with separately.)**
- Occasionally, a fishy odour will occur if the source water is of a high pH, typically greater than 8.0. If this occurs, putting the unit through a couple regeneration cycles can sometimes reduce the odour. Chlorine in combination with a higher pH can also make the odour worse or more difficult to overcome as chlorine degrades the resin in the OCR unit.
- Depending on the alkalinity of the source water being treated, the chlorides in the treated water from the OCR unit will increase proportionally. This may result in a bitter salty taste which should be treated with a reverse osmosis drinking water system for household drinking and cooking water.

## Installation and Start-up Procedure

### CAUTION:

If the ground from the electrical panel or breaker box to the water meter or underground copper pipe is tied to the copper water lines and these lines are cut during installation of the Noryl bypass valve and/or poly pipe, an approved grounding strap must be used between the two lines that have been cut in order to maintain continuity. The length of the grounding strap will depend upon the number of units being installed and/or the amount of copper pipe being replaced with poly. See Figure 1.

In all cases where metal pipe was originally used and is later interrupted by poly pipe or the Noryl bypass valve as in Figure 2 or by physical separation as in Figure 3, to maintain proper metallic pipe bonding, an approved ground clamp c/w not less than # 6 copper conductor must be used for continuity.

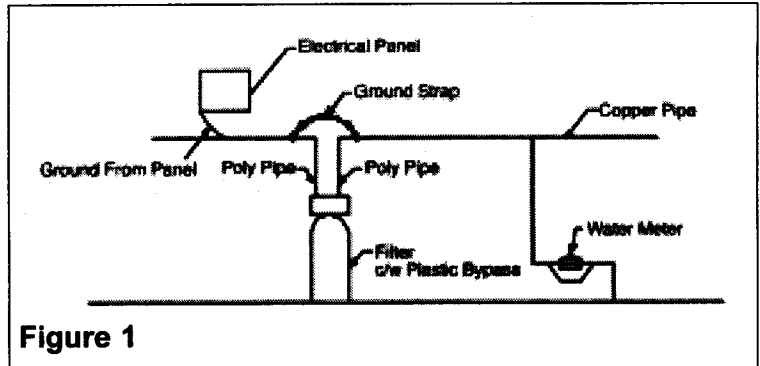

Figure 1

Check your local electrical code for the correct clamp and cable size.

1. Determine the best location for your OCR unit, bearing in mind the location of your water supply lines, drain line and 120 volt AC electrical outlet. Subjecting the OCR unit to freezing or temperatures above 49°C (120°F) will void the warranty.
2. Familiarize yourself with the location of the inlet, outlet and drain on the control valve. Be very careful not to get the controls wet.
3. The inlet and outlet of the valve are marked with arrows. Attach the bypass to the control valve. When sweat fittings are used, solder the adapters for the inlet and outlet to a short length of copper pipe first. This procedure is necessary because the controls **MUST NOT** be subjected to temperatures above 16° F. Then, using teflon tape, screw the adapters for the inlet and outlet into the valve.

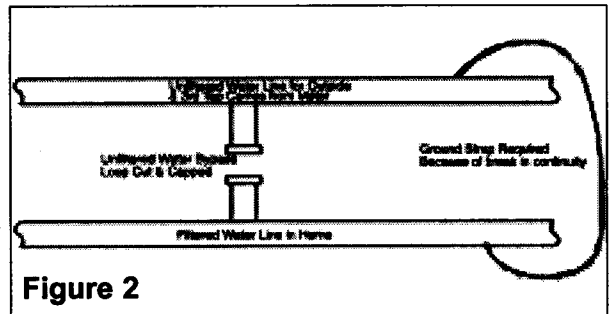

Figure 2

**CAUTION - do not use pipe thread compound as it may attack the material in the valve body.**

On the drain, using teflon tape, attach the 1/2" hose barb supplied (Do not overtighten) and a full 1/2" hose for the drain line. A restriction at the drain can cause any automatic water conditioner to malfunction. Place the unit in position and complete the plumbing necessary for the installation. Generally, water to outdoor faucets and sprinklers should not be treated.

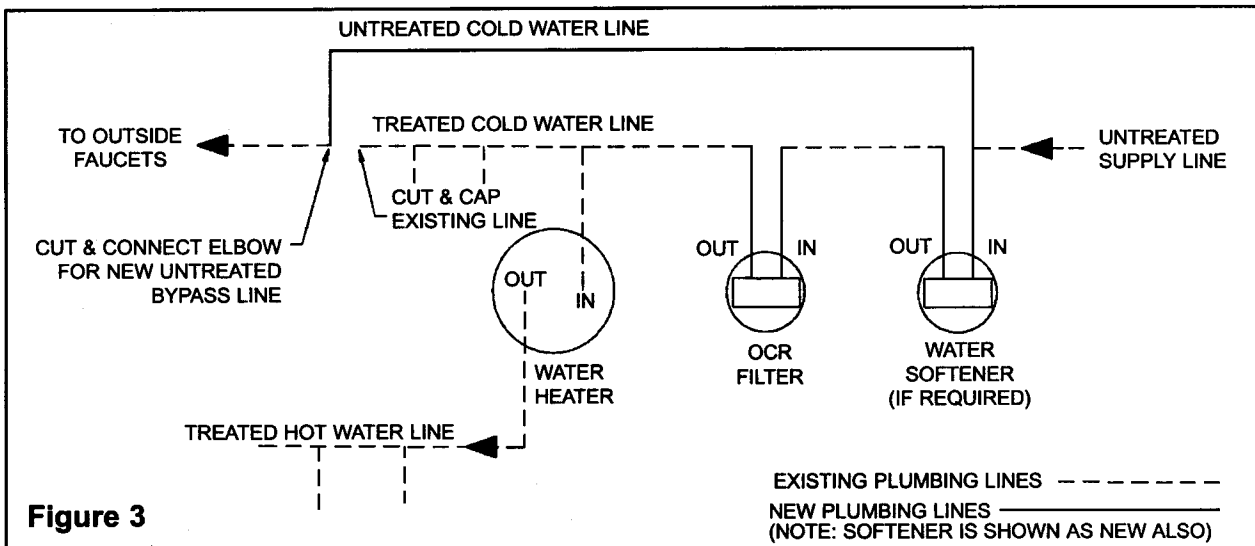

Figure 3

## Installation and Start-up Procedure cont...

OCR Filters are also supplied with brass service line flow controls, similar to the one shown in Figure 4. OCR15 and OCR2° size filters are supplied with #15177 flow control housing and flow button with 3/4" x 1/2" FNPT connections. OCR3° size filters are supplied with #1948° flow control housing and flow button with 3/4" x 3/4" FNPT connections. The installation of this flow control ensure the recommended service flowrate of the OCR filter is not exceeded. If this flow control is not installed, some colour may bleed through at higher flow rates.

Thread the flow control onto the threaded OUTLET of the bypass and yoke assembly. Only use teflon tape to seal the threads of the bypass and yoke assembly as pipe thread compound may attack the material. Ensure the flow control indicates the direction of flow.

**CAUTION - Check service line flow control direction of flow arrow and only thread onto the service outlet line.**

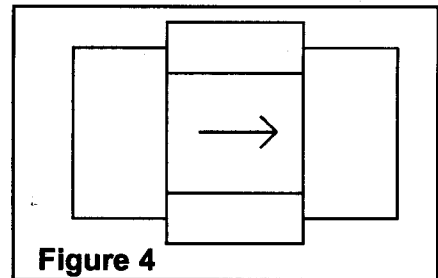

Figure 4

4. Water to supply outside faucets used to water lawns and gardens is typically not treated. A new water line is often required to be connected to supply untreated water to the inlet of the OCR and to the outside faucets. Cut the water line between where it enters the house; before any lines that branch off to feed water heater or other fixtures in the house; and as near the desired location of the water softener as possible. Install a tee fitting on the feed end of the cut pipe and an elbow on the other end. Install piping from the tee of the water softener and from the elbow to the outlet to the softener. To sever the water lines which branch off to feed outside faucets, cut the branch lines approximately two inches from the fitting on the main water line. Install an elbow on the end of the pipe nearest the outside faucet and a cap on the end connected to the existing water line. Install piping from the tee on the inlet line to the water softener to the elbow on the pipe to the outside faucet. Following this procedure will result in all lines in the house, with the exception of the outside faucets but including the water heater and therefore the hot water lines, being supplied with treated water.
5. Plug the OCR unit in.
6. Manually turn the manual regeneration knob to the backwash position. (See Page 5 & Figure 6 - Page 5) Slowly turn on the water supply to the valve until all the air clears. Allow the water to run to the drain for 2 to 3 minutes or until the water is clear.
7. Manually turn the Manual Backwash Knob on the timer slowly through backwash, brine draw, fast rinse to the Brine Tank Refill cycle. Once in the Brine Tank Refill cycle, allow valve to fill tank automatically. The correct amount of water is automatically metered into the air check tube in the brine well into the brine tank. The Brine Tank Refill cycle can be located by observing the drain line and watching the movement of the piston gear (see figure 5) on the valve. These cycles are as follows:

- 1st cycle is BACKWASH : Valve should cycle to position and water should begin flowing to drain rapidly.
- 2nd cycle is BRINE DRAW: Valve should cycle to next position, water will continue to flow to drain slowly.
- 3rd cycle is FAST RINSE: Valve should cycle to next position, water will continue to flow to drain rapidly.
- 4th cycle is BRINE TANK REFILL: Valve should cycle to next position, water will STOP flowing to drain and water will begin flowing into the brine tank.

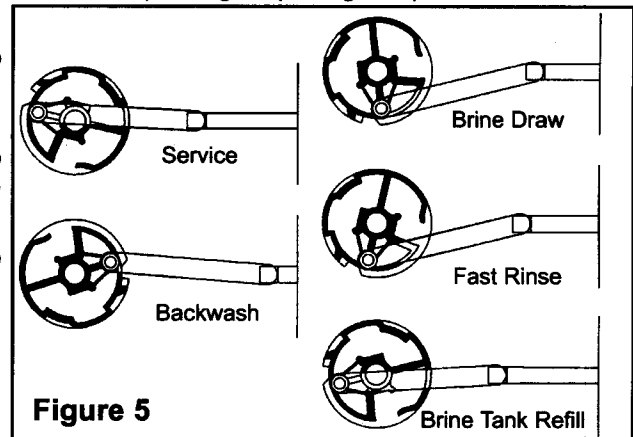

Figure 5

8. Set the 24 hour timer and frequency of regeneration following instructions on page 5.
9. Replace timer cover.
10. Fill the brine tank with approved water softener salt.
11. Wait approximately four (4) hours for water in brine tank to fully dissolve salt.
12. Move the bypass valve to the normal service position. (See Page 6, Figure 7)
13. Initiate a manual regeneration. This will take approximately 1-1/2 - 2 hours to complete. once the valve returns to service automatically, water to service can be used.
14. It is suggested that for the first couple service/regeneration cycles the colour of the water be closely monitored. If colour begins to break through prior to the calculated amount set, the gallonage setting should be reduced accordingly.

**ALL GOVERNMENT CODES GOVERNING INSTALLATIONS OF THESE DEVICES MUST BE OBSERVED.**

## Operating Instructions: Organic Colour Removal Filters Meter Initiated Models

### 1. How To Set Time Of Day:

Press and hold the red button in to disengage the drive gear.

Turn the large gear until the actual time of day is at the time of day pointer.

Release the red button to again engage the drive gear.

### 2. Time Of Regeneration:

The time of regeneration is factory set at 2:00 am. Adjustment of this time can be achieved by simply adjusting the time of day on the 24 hr. gear.

### 3. How To Manually Regenerate Your Water Conditioner At Any Time:

Turn the manual regeneration knob clockwise.

This slight movement of the manual regeneration knob engages the program wheel and starts the regeneration program.

The black center knob will make one revolution in the following approximately three hours and stop in the position shown in the drawing.

Even though it takes three hours for this center knob to complete one revolution, the regeneration cycle of your unit might be set only one half of this time.

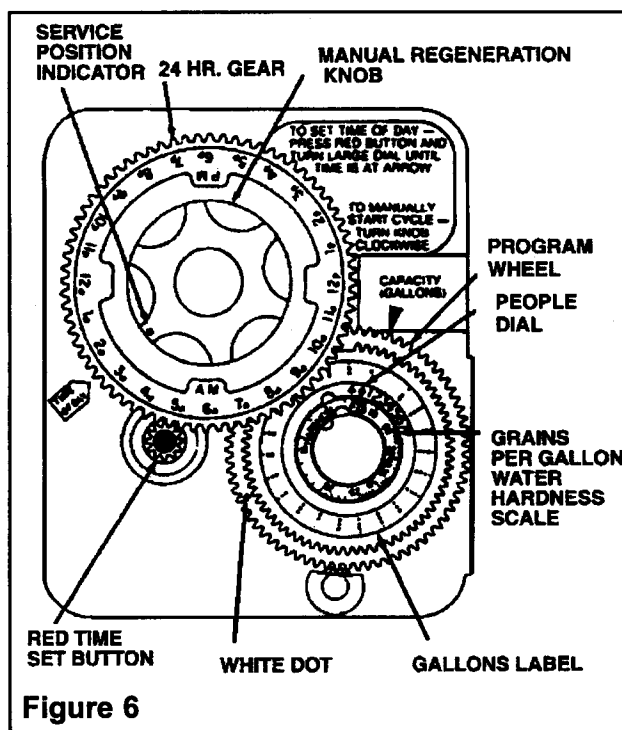

**Figure 6**

In any event, conditioned water may be drawn after rinse water stops flowing from the water conditioner drain line.

### 4. Setting The Frequency Of Automatic Regeneration:

The frequency of automatic regeneration can be set by using the Gallon Label and the small white dot on the Program Wheel. To set the Program Wheel, grasp it, and while pulling it towards you, turn it until the desired number of gallons is aligned with the white dot on the circumference. The number of gallons is read by multiplying the number on the label by 100. To determine the number of gallons of treated water that can be produced between regenerations, use the following formula:

$$\begin{aligned}
 & \text{Capacity of your OCR Filter (See Specifications Page 1)} \\
 & \div \text{ ppm of tannins in water sample.} \\
 & = \text{ No. of Gals. between regeneration} \\
 & - \text{ Reserve (No. of people x 75 gals.)} \\
 & = \text{ No. of Gals. at which to set the program wheel}
 \end{aligned}$$

**Important Note -** Due to the nature of the interaction between the colour producing organic molecules and the resin bed in your OCR filter, we recommend OCR filters be regenerated a minimum of every 3 days. If the calculated capacity allows a service run longer than 3 days (on average) between regenerations, the set gallonage should be reduced accordingly. This is to extend the life of the resin bed in your OCR filter.

# Operating Instructions: General

## Water Pressure

Your OCR unit is designed to operate under normal water pressures from 2° psi to 12° psi.

## Regeneration and Automatic Bypass

OCR units are factory set to regenerate at 2:00 a.m. during a period of little or no water use. The regeneration cycle lasts approximately three hours, after which treated water service is restored. While regeneration is taking place, untreated water automatically bypasses the water conditioner if required. Use of water, particularly hot water, should be avoided at this time to prevent untreated water from filling the water heater.

## Manual Bypass (Figure 7)

In case of an emergency such as an overflowing brine tank, you can isolate your OCR filter from the water supply using the bypass valve located at the back of the control.

In normal operation the bypass is open with the ON/OFF knobs in line with the INLET and OUTLET pipes. To isolate the softener, simply rotate the knobs clockwise (as indicated by the word BYPASS and arrow) until they lock.

You can use your water related fixtures and appliances as the water supply is bypassing the OCR filter. However, the water you use will be untreated.

To resume treated water service, open the bypass valve by rotating the knobs counter-clockwise.

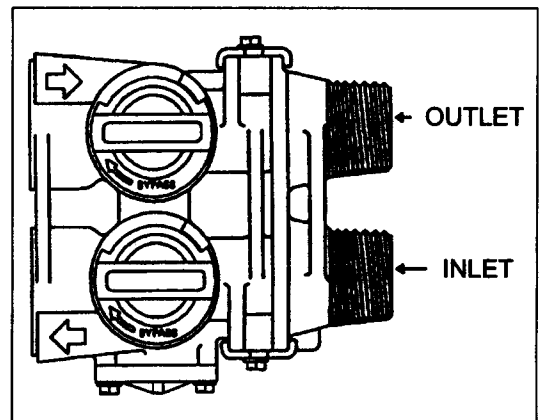

Figure 7

## New Sounds

You will notice new sounds, such as the hum of the timer, as your OCR filter operates. During regeneration, it will not be uncommon to hear the sounds of water running to the drain.

## Maintenance Instructions

Maintenance of your new OCR filter requires very little time or effort, however, it is essential. Regular maintenance will ensure many years of trouble free and efficient operation.

### Adding Salt

Use only water softener approved salt for your OCR filter. Check the salt level monthly. It is important to maintain the salt level above the water level. To add salt, simply lift the salt lid and add the salt directly into the brine tank. Be sure the brine well cover is on and fill only to the height of the brine well.

#### Caution

Liquid brine will irritate eyes, skin and open wounds. Gently wash exposed area with fresh water. Keep children away from your water conditioner.

### Resin Cleaner

An approved resin cleaner **must** be used on a regular basis if your water supply contains iron. The amount of resin cleaner and frequency of use is determined by the quantity of iron in your water (consult your local representative or follow the directions on the resin cleaner package).

### Care of Your OCR Filter

To retain the attractive appearance of your new OCR filter, clean occasionally with a mild soap solution. Do not use abrasive cleaners, ammonia or solvents. Never subject your conditioner to freezing or to temperatures above 12° °F.

### Bridging (Figure 8)

Humidity or the wrong type of salt may create a cavity between the water and the salt. This action, known as "bridging", prevents the brine solution from being made, leading to your water supply being untreated.

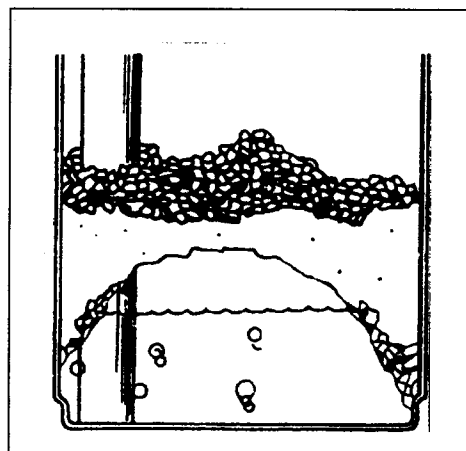

Figure 8

If you suspect salt bridging, carefully pound on the outside of the plastic brine tank or pour some warm water over the salt to break up the bridge. This should always be followed up by allowing the unit to use up any remaining salt and then thoroughly cleaning out the brine tank. Allow four hours to produce a brine solution, then manually regenerate the OCR filter.

### Cleaning the Injector Assembly (Figure 9)

Sediment, salt and silt will restrict or clog the injector. A clean water supply and pure salt will prevent this from happening.

The injector assembly is located on the left side of the control valve. This assembly is easy to clean.

Shut off the water supply to your OCR filter and reduce the pressure by opening a cold soft water faucet. Using a screwdriver, remove the two screws holding the injector assembly to the control valve body. Carefully remove the assembly and disassemble as shown in Figure 1°. The injector orifice is removed from the injector body by carefully turning it out with a large screwdriver. Remove the injector throat the same way. Carefully flush all parts with water. Use a mild acid such as vinegar or **Pro-Rust Out** to clean the small holes in the orifice and throat.

Reassemble using the reverse procedure.

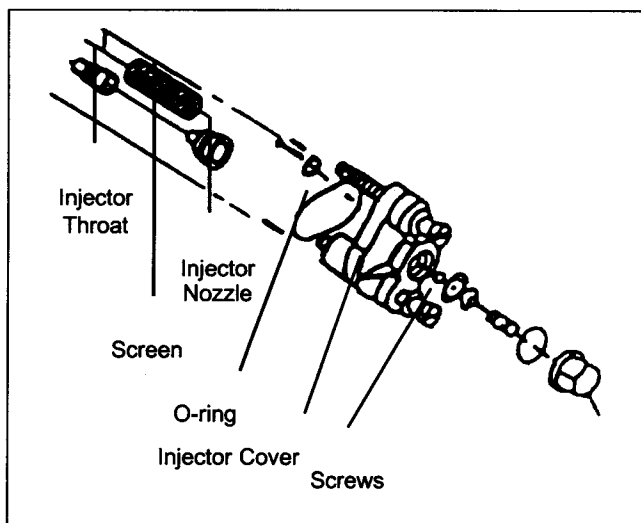

Figure 9

## Trouble Shooting your Organic Colour Removal unit

<b>Problem: Fishy or unpleasant odour is apparent in the treated water that is not present in the untreated water.</b>	
1. pH of the incoming water may be high.	<ul style="list-style-type: none"> <li>This odour may be apparent on startup and will typically be reduced or eliminated after a couple service runs and regenerations cycles of the OCR filter.</li> </ul>
2. pH of the incoming water maybe high in combination with chlorine present for disinfection.	<ul style="list-style-type: none"> <li>The addition of chlorine along with high pH typically increases the chances that an odour will be present in the treated water With the presence of chlorine, it is unlikely odour will be eliminated. Chlorine can be removed through the use of an activated carbon filter, however it is highly recommended that additional disinfection methods be re-employed downstream of the OCR filter with Ultraviolet Sterilizers or Chlorination Pumps.</li> </ul>
<b>Problem: OCR unit was removing colour from water, but then starts to show colour again until regeneration. Then colour is removed again.</b>	
1. Capacity of OCR unit is being overrun and resulting in tannins not being removed near the end of service run.	<ul style="list-style-type: none"> <li>Decrease the gallons between service runs to a point where no coloured water is appearing between one regeneration to the next.</li> </ul>
<b>Problem: OCR unit was removing colour from water, but then starts to show colour earlier and earlier into service run.</b> <b>OR</b> <b>Problem: OCR unit was removing colour from water, but no longer seems to be effective.</b>	
1. Regeneration is not being performed adequately.	<ul style="list-style-type: none"> <li>Check to see if salt is in brine tank. If no salt is present, last regeneration(s) may have been done without salt brine. Add salt to brine tank and manually regenerate OCR until after allowing brine to dilute in water for at least four (4) hours.</li> <li>Check to see if brine tank is being refilled with water properly at the end of the regeneration cycle and/or if water is being drawn into the valve during the brine draw cycle. Injector &amp; Screen or Brine Valve may be plugged and require cleaning.</li> <li>Check to see that valve settings are correct.</li> </ul>
2. Regeneration is not being performed at all.	<ul style="list-style-type: none"> <li>Check gallonage setting between regenerations. Capacity set may be too large.</li> <li>Check to see that meter is turning and properly connected via the meter cable to the timer.</li> <li>Check to ensure that Bypass Valve is not open and bypassing the OCR unit with untreated water.</li> </ul>
3. Resin Media may be backwashing to drain.	<ul style="list-style-type: none"> <li>Confirm backwash flow control is installed on drain line and check that backwash flow control has not been swapped for service line flow control.</li> <li>Monitor drain line during regeneration cycle and check that no resin beads are exiting the OCR unit.</li> </ul>
4. OCR unit resin media may be fouled with organics. Check resin visually to confirm.	<ul style="list-style-type: none"> <li>Try manually regenerating OCR unit two or three times in a row. Allowing approximately four (4) hours between regenerations to allow salt brine to be saturated.</li> </ul>



	<ul style="list-style-type: none"> <li>• Add small amount of Soda Ash to the brine well. Allow time to mix with saturated brine solution and perform a manual regeneration. <b>Recommended Product: PRO SODA ASH</b> – see instructions for <u>cleaning tannin water softeners</u> on bottle.)</li> <li>• As a last resort, try adding approximately four (4) ounces of household bleach (5.25%) into the brine well. Begin a manual regeneration. Monitor the drain line for a strong chlorine odour which should occur in the brine draw cycle . When odour is present, halt regeneration by unplugging unit and shutting down water flow to the OCR unit via the bypass valve. Shutdown OCR unit for approximately two (2) hours, then continue regeneration by plugging unit back in and replacing bypass valve to service position. Only try this step as a last resort as chlorine will degrade the resin bed. If unsuccessful, see next step.</li> <li>• Resin bed may have become permanently fouled due to infrequency of regenerations or nature of tannins causing colour in water. Replace resin media bed and check to see that regeneration frequency is adequate or consult your dealer.</li> </ul>
<p>5. OCR filter resin media may be fouled with Iron. Check visually to confirm.</p>	<ul style="list-style-type: none"> <li>• Iron should typically be removed prior to the OCR unit. Install an iron filter upstream of OCR unit or if small amounts of iron are being removed with a softener, check to see that water softener is working correctly.</li> <li>• Clean iron from resin media bed with a reducing agent such as sodium bisulfite or sodium hydrosulfite by adding it to the brine tank down the brine well and allowing time to mix. Manually regenerate softener. <b>Recommended Product: PRO RUST OUT</b> – see instructions on bottle on cleaning of water softeners.</li> <li>• If resin bed cannot be cleaned, it may be permanently fouled with iron. Replace resin media bed and install treatment upstream of OCR unit to remove iron.</li> </ul>
<p>6. OCR filter resin media may be fouled with Calcium Carbonate.</p>	<ul style="list-style-type: none"> <li>• Calcium Carbonate fouling is the result of hardness precipitating onto the resin media. If a softener is installed, check to see that it is functioning properly. If no water softener is installed, have a water analysis done to confirm hardness and install water softener upstream of OCR unit.</li> <li>• Clean calcium carbonate from resin media with a mild acid solution such as phosphoric acid. Do this by adding cleaning product to the brine tank via the brine well and then manually regenerate. Once complete, manually regenerate again with salt brine. <b>Recommended Product: PRO Res-Care</b> – see instructions on bottle on cleaning of water softeners.</li> </ul>

**Problem: OCR unit appear to be causing a high pressure drop in home water system.**

<p>1. Pressure drop may be due other factors.</p>	<ul style="list-style-type: none"> <li>• Confirm pressure loss is due to the OCR unit, and not the result of distribution or well pump problem.</li> <li>• Confirm pressure loss is due to OCR unit by checking flow while in BYPASS mode.</li> <li>• Check that flow demand is not exceeding rated flow rate of OCR unit. OCR units are supplied with a SERVICE LINE FLOW CONTROL to ensure maximum effectiveness is maintained. Attempting to exceed this flow control rating will result in a pressure drop. OCR unit should be increased in size to compensate for larger demand.</li> </ul> <p><b>NOTE: Do not remove this FLOW CONTROL from valve outlet. It will likely result in a decrease in OCR unit performance.</b></p>
<p>2. Pressure loss may be due to fouling from Organics, Iron or Calcium Carbonate.</p>	<ul style="list-style-type: none"> <li>• See troubleshooting notes above on dealing with fouling problems.</li> </ul>
<p>3. Pressure loss may be due to Resin Media being plugged with Silt and Turbidity.</p>	<ul style="list-style-type: none"> <li>• Try manually regenerating OCR unit and extending the backwash by unplugging unit during the first cycle that begins to send water to the drain. Monitor water to the drain and watch for dirt and silt. If present, continue this backwash cycle until water runs clear then plug unit and allow valve to finish regeneration normally.</li> <li>• Install multi-media filter or 5 micron cartridge filter ahead of OCR unit to remove Silt and Turbidity.</li> </ul>

**Problem: OCR unit appears to be removing most of the colour in the water, but some still passes through.**

<p>1. Raw water may be partially slipping past OCR unit OR the Organics (Tannins) not being removed may be impervious to the resin media in the OCR unit.</p>	<ul style="list-style-type: none"> <li>• Check to see that SERVICE LINE FLOW CONTROL is in place on the valve outlet. Flowrates higher than recommended through the OCR unit may be causing some leakage of colour.</li> <li>• Check to see that BYPASS valve is not partially open and bleeding some raw water to distribution lines.</li> <li>• Check that pipelines after OCR unit are not lined with organics that are slowly being stripped away. Lines may require flushing.</li> <li>• If all equipment and distribution sources of problem have been eliminated, consult your water treatment dealer, who may try to "polish" the remaining colour after the OCR unit with an ACTIVATED CARBON filter or cartridges or other treatment method.</li> </ul>
---	---

# Guarantee

**USF WaterGroup Inc.** guarantees that your new water conditioner is built of quality material and workmanship. When properly installed and maintained, it will give years of trouble-free service.

**Five Year Complete Parts Guarantee:**

**USF Watergroup Inc.** will replace any part which fails within 60 months from date of manufacture as indicated by the serial number, provided the failure is due to defect in material or workmanship. The only exception shall be when proof of purchase or installation is provided and then warranty period shall be from the date thereof.

**Lifetime Guarantee on Mineral Tanks and Brine Tanks:**

**USF WaterGroup Inc.** will provide a replacement mineral tank or brine tank to any original equipment purchaser in possession of a tank that fails within his/her lifetime, provided that the water conditioner is, at all times operated in accordance with specifications and not subject to freezing.

**General Provisions:**

**USF WaterGroup Inc.** assumes no responsibility for consequential damage, labor or expense incurred as a result of a defect or for failure to meet the terms of these guarantees because of circumstances beyond its control.



580 Park Street, Regina, Saskatchewan, S4N 5A9  
265 Industrial Road, Cambridge, Ontario, N3H 4R9